



The original

**The industry benchmark.
Second generation.**

Demag DC-II chain hoist

DEMAG

Quality. Performance. Demag DC-II chain hoist.

The Demag DC-II chain hoist meets high standards of quality and innovation. With its second generation, Demag is consistently following the DC path and once again defining the industry benchmark. Naturally made in Wetter.

INNOVATION FROM WETTER.

Like its predecessor, the DC-II offers the most comprehensive standard equipment and also a wide-ranging option package, which underscores the flexible application possibilities of the hoist and its modular design.

The high-quality components of the chain hoist meet all the demands of 'made by Demag' quality. In-house gearbox production and assembly at the main plant in Wetter epitomise the expertise that has established the DC as an industry benchmark.

SECOND GENERATION. FULLY EQUIPPED INSTEAD OF A LIST OF EXTRAS.

The main components of the DC-II are maintenance-free for up to ten years. Easy adjustment options without the need for special tools and the Plug&Lift principle characterise the service-friendliness of this hoist.

Safety during operation is underlined by the slipping clutch with automatic cut-off through speed monitoring. In addition, 24 V contactor control, operating limit switches and elapsed operating time counter ensure safe operation with the DC-II.



Demag DC-II chain hoist

From its inception, the DC-II is available in pre-configured variants with load capacities from 125 to 1,000 kg direct from stock. The basic DC-Com II variant and the high-end DC-Pro II variant differ in terms of their classification in the FEM / ISO group of mechanisms and their lifting speeds. Both variants of the DC-II have the same high level of equipment.



IMMEDIATELY AVAILABLE

With the market launch, Demag is offering three sizes (DC-II 1/2, DC-II 5 and DC-II 10) as pre-assembled chain hoists. The benefits for you are fast availability and perfect harmonisation of the tried-and-tested components. These chain hoists, which are available direct from stock, feature safe, low-wear and ergonomic 1/1 reeving. With the 2m to 4m groups of mechanisms, they can achieve up to 6,300 hours of service.

YOUR LIFTING HEIGHTS

- DC-Pro II 5 metres
- DC-Com II 4 metres

With the two speed settings, you can select a high operating speed with the powerful V2 and a sensitive positioning speed with V1.

The transition of the existing chain hoist range to the new generation is ongoing. Once it is complete, the entire DC chain hoist range will be available in the new DC-II generation.





DEMAG

Benefits of the Demag DC-II chain hoist

43009

DEMAG SETS THE INDUSTRY BENCHMARK

- Standard version is already fully equipped
- Two lifting speeds as standard
- Proven 24 V contactor control
- Operating limit switch (top/bottom)
- Elapsed operating time counter and status display
- Powder-coated aluminium housing parts
- Height-adjustable control cable for ergonomic operation
- Duty cycle: 60% (40/20), 360 s/h at 45°C, can be used up to 60°C
- Signal design for three-axis applications
- Suspension bracket for improved C-dimension and simple installation

Quick to install. Easy to maintain.

The components of Demag DC-II hoists are designed for long-term maximum performance. During annual maintenance, adjustment work or service operations, work on the chain hoist can be carried out easily and without special tools.

■ Main components are maintenance-free

- Gearbox and slipping clutch maintenance-free for up to 10 years
- Brake maintenance-free for up to 10 years (DC 10 up to 5 years)

■ Brake with up to 1.5 million cycles thanks to smart Demag tristate control system

- Low-wear brake due to regenerative braking
- No brake adjustment required
- No brake bonding thanks to double-encapsulated brake
- No load sagging, as the brake is located in the load-bearing arrangement before the slipping clutch

■ Quick installation

- Easier access thanks to well thought-out screw concept
- Simple and quick maintenance and servicing of individual components thanks to the modular design of the chain hoist – reducing downtimes
- Hinged suspension bracket allows the chain hoist to be suspended only after the trolley has been fitted

■ Easy maintenance and quick replacement of components

- Replaceable gearbox components
- Replaceable contactor and relay
- Modified adjustment of the slipping clutch without special tool, performed by axial screw
- Service cover for quick access to plug connections, strain relief, compartment for control cable (3 m) and chain drive
- Chain lubrication through lubrication hole in the chain guide for better joint lubrication
- Reduced downtimes thanks to replacement of the entire chain drive without the need to remove motor and gearbox parts
- Maximum robust chain drive in sandwich design for long-term service, even under difficult operating conditions



43087

Safety by Demag

Demag DC-II hoists feature useful safety features as standard to make daily work not only more efficient, but above all safer. Low voltage at the direct contact point on the pendant controller as well as assistance and convenience functions of the smart Demag tristate control system.

- Safety-related functions satisfy Performance Level c and Category 2 and higher as per EN ISO 13849-1
- Load reliably held in any operating situation, no load dropping at rest thanks to brake in the load train before the slipping clutch
- Automatic braking in case of control failure
- Standards met with reference to functional safety
- Chain hoist and travel drive with protection class IP 55, insulation class F
- Pendant controller operated with low voltage thanks to 24 V contactor control
- All electric connections plug in – “Plug & Lift” and “Plug & Drive”
- Smart Demag tristate control system
 - No harmful continuous slipping thanks to speed monitoring
 - Reliable protection against extreme overload
 - Only one control cable for 1–3 motion axes
- Infrared diagnostic interface with IDAPSY software (for reading out and managing specific data)



Quality down to the last detail

As soon as Demag lettering adorns the cover, the product stands for quality. Demag DC-II chain hoists consist of high-quality assemblies and components that are designed for harsh conditions and long-term service. Essential components such as the gearbox, brake and slipping clutch are maintenance-free for up to 10 years.



- Generously dimensioned gearbox:
 - 20% longer service life thanks to Demag FEM-Plus
 - Group of mechanisms 2m+ (1,900 hours) for the main load capacities
 - Group of mechanisms up to 4m (6,300 hours) for demanding applications
 - High classification in the new A classes and Dh classes with reference to operating cycles
- All chain hoist assemblies are designed for a long service life, even under the toughest conditions
- Reliable operation from -20°C to +45°C without derating of duty cycle
- Can also be used up to 60 °C and above
- Hoist motor with large safety reserves
 - ensures reliable operation for many years
 - allows switching cycles far above the usual level on the market
- Less chain wear thanks to 1/1 reeving up to 1,000 kg
- More robust chain guide as standard
- Powerful cylindrical-rotor motor with fan and separate direct current brake
- Thermal motor contact as standard

GROUP OF MECHANISMS TO FEM / ISO

Hoist units are classified according to FEM/ISO in accordance with DIN EN 14492-2 and are calculated on the basis of the average of the operating time, the load on the hoist unit and the lifting distances travelled per day. The result is the maximum service life of the hoist unit under full load.

FEM / ISO	Operating hours
1Am / M4	800
2m / M5	1,600
2m+ / M5+	1,920 Service life +20%
3m / M6	3,200
4m / M7	6,300

Convenient and efficient material handling

Every transport operation has the potential to save time. Matching Demag components ensure precision in every lifting motion and thus greater efficiency through faster positioning. The high-quality feel of Demag products is reflected in the ergonomic pendant controllers. Thanks to the adjustable control cable length, these can be adjusted to the right operating height in no time at all and thus ensure better ergonomics at the workplace.

- High-quality and sensitive parts can be moved and positioned more gently and safely
 - Smooth starting and braking of the motor ensures low-sway load handling
 - Precise positioning thanks to powerful motor and matching components
 - Powerful operating speed (V2)
 - Precise positioning speed (V1)
- Height-adjustable DSC pendant controller with low-fatigue actuating forces
- Tailored to meet individual needs. No wiring required.
 - Control cable length
 - Pendant controller position
 - Unused control cable is stored under the service cover
- Reduced operating noise thanks to helical gearing in all gearbox stages
- Smooth operation due to high-quality gearing



Sharp. Sharper. 7-segment display.

A glance up at the Demag DC-II chain hoist gives the operator an overview of the current operating status of the chain hoist. In real time. The zoom function enlarges the display for the viewer and ensures better visibility even with higher suspensions.

MORE OPTIONS FOR YOUR SOLUTION

The variety of options for the DC-II is reflected in its possible installation positions and, for example, the possibility to install a rain canopy.

- Various mounting points directly on the motor
- New bolting points on the top of the gearbox for easy attachment of options
- Optional rain canopy or heat deflector



7-SEGMENT DISPLAY

- Elapsed operating time counter, status and error display
- Always well informed for service purposes
- With zoom function for better visibility



WELL DOCUMENTED, AVAILABLE AROUND THE CLOCK

More information at the click of a button with the Demag DDS documentation system.

- Product description
- Operating instructions
- Technical data
- Spare parts lists

Made in Wetter an der Ruhr

Our production facility has been manufacturing crane and lifting equipment, and industrial drives in Wetter an der Ruhr for over 200 years. This centuries-long expertise in the development and manufacture of solutions for lifting loads is reflected in Demag's high understanding of quality.



The DC-II gearbox is still manufactured in-house by Demag. This is the only way for us to meet our demanding quality requirement for the chain hoist.



Direct from stock. Quality from Wetter.

43093

43063

Technical data

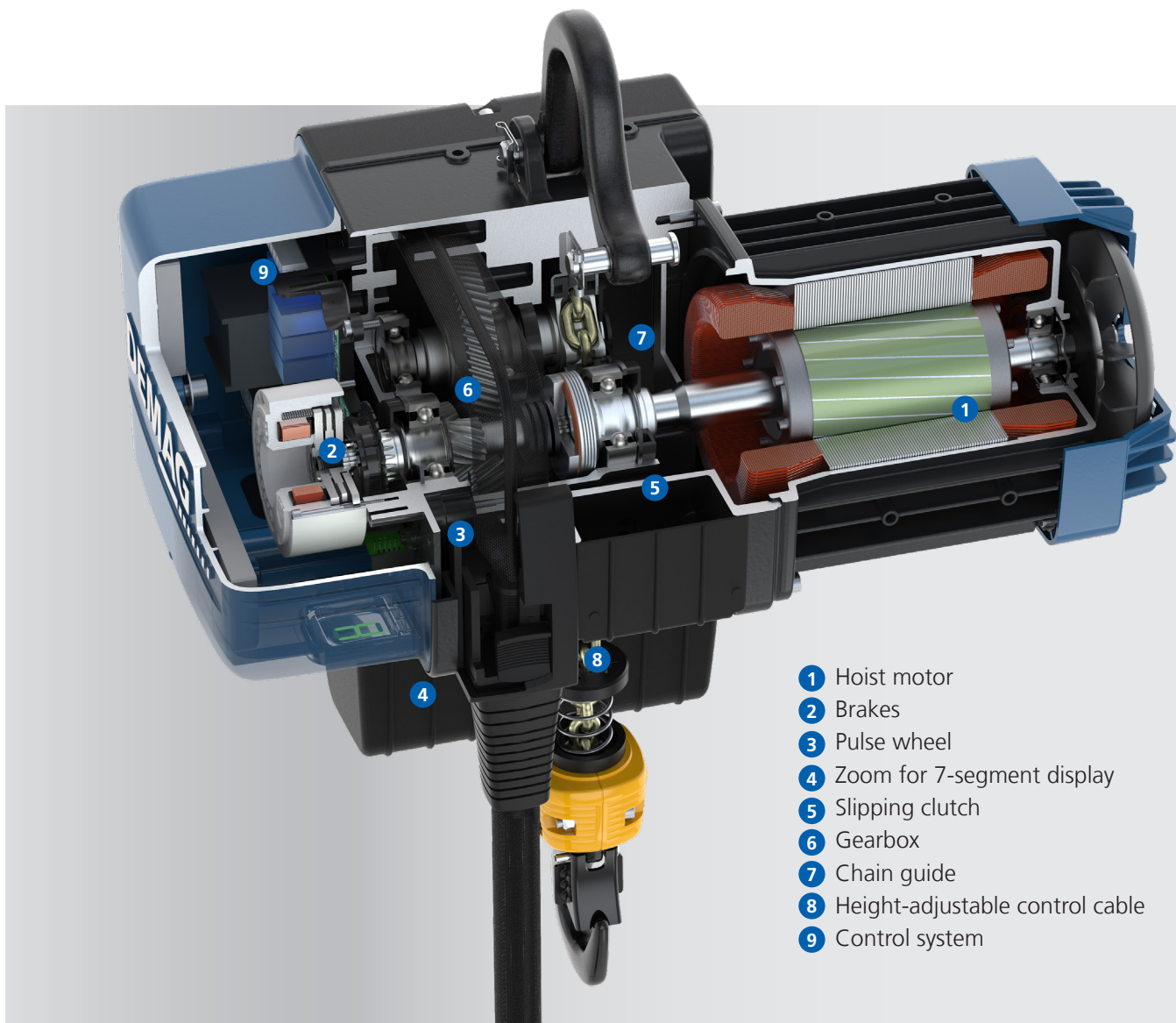

- 1 Hoist motor
- 2 Brakes
- 3 Pulse wheel
- 4 Zoom for 7-segment display
- 5 Slipping clutch
- 6 Gearbox
- 7 Chain guide
- 8 Height-adjustable control cable
- 9 Control system

Chain hoist	Size	Load capacity [kg]	Reeving	Group of mechanisms		Lifting height [m]	Lifting speed [m/min]	Supply voltage [V/Hz]
				FEM / ISO	A/Dh Classes			
DC-ComA II 1-125 1/1 H4 V8/2	1	125	1/1	3m/M6	A7/Dh2	4	8 / 2	380 - 415 / 50
DC-Pro II 1-125 1/1 H5 V8/2	1			4m/M7	A7.8/Dh2	5	8 / 2	
DC-ComA II 2-250 1/1 H4 V6/1,5	2	250	1/1	2m/M5	A5/Dh2	4	6 / 1.5	380 - 415 / 50
DC-Pro II 2-250 1/1 H5 V8/2	2			2m+/M5+	A6/Dh2	5	8 / 2	
DC-ComA II 5-500 1/1 H4 V4/1	5	500	1/1	2m/M5	A5/Dh2	4	4 / 1	380 - 415 / 50
DC-Pro II 5-500 1/1 H5 V8/2	5			2m+/M5+	A6/Dh2	5	8 / 2	
DC-ComA II 10-1000 1/1 H4 V4/1	10	1.000	1/1	2m/M5	A5/Dh2	4	4 / 1	380 - 415 / 50
DC-Pro II 10-1000 1/1 H5 V6/1,5	10			2m+/M5+	A5.6/Dh2	5	6 / 1.5	

2m+/M5+: Lifetime +20%

*A7.8 = 500.000 cycles with additional 80% cycles: 900.000 cycles

* A5.6 = 125.000 cycles with additional 60%cycles: 200.000 cycles

The chain hoists are offered in a fixed version, with manual trolley (U11) or with electric trolley (E11). Available for flange widths of 58-200 mm or 201-310 mm.

DEMAG CRANES & COMPONENTS GMBH

Wetter site

Ruhrstrasse 28

58300 Wetter, Germany

E info@demagcranes.com

T +49 2335 92-0

F +49 2335 92-7676

www.demagcranes.com

DEMAG
.....